

Montageanleitung

Assembly instructions / Instructions de montage / Montage instructies / Istruzioni per il montaggio



- DE** Montage nur durch in der Elektrotechnik ausgebildete Installateure! Liegen keine entsprechenden Fachkenntnisse vor, so kann es zu einer unsachgemäßen Montage kommen, die die Sicherheit des Produktnutzers gefährdet.
- EN** Installation should be performed only by trained electricians! If no suitable professional staff are available installation may be performed incorrectly, putting the safety of users at risk.
- FR** Seuls des installateurs ayant suivi une formation d'électrotechnicien sont autorisés à effectuer le montage! Si le montage est effectué par un collaborateur ne disposant pas des connaissances spécifiques, l'installation risque d'être non conforme et d'entraîner des risques pour la sécurité de l'utilisateur.
- NL** De montage dient uitsluitend door installateurs met voldoende elektrotechnische kennis te worden uitgevoerd. Onvoldoende vakkundigheid kan tot onjuiste montage leiden die de veiligheid van de gebruikers in gevaar kan brengen.
- IT** Montaggio esclusivamente da parte di specialisti qualificati. Nel caso che il montaggio sia effettuato da un collaboratore senza formazione adeguata, l'installazione può essere difettosa e causare danni all'utente.

KAISER GmbH & Co. KG

Ramsloh 4 · 58579 Schalksmühle

DEUTSCHLAND

Tel.+49(0)2355.809.61 · Fax+49(0)2355.809.21

technik@kaiser-elektro.de

www.kaiser-elektro.de

UP¹ ECON[®] Fix

Montage mit Schnellfixierung / Assembly with quick fixing / Montage avec fixation rapide / Montage met snelverbinder / Montaggio con fissaggio rapido

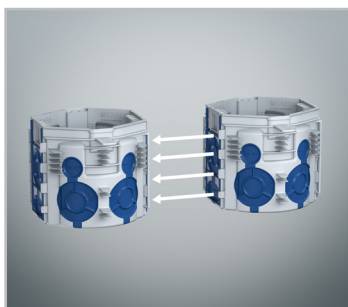
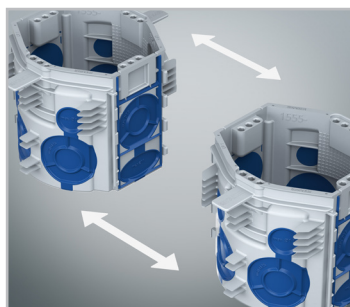
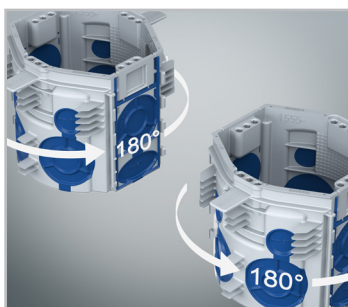

UP¹ ECON[®] Fix

Montage mit Schnellfixierung / Assembly with quick fixing / Montage avec fixation rapide / Montage met snelverbinder / Montaggio con fissaggio rapido

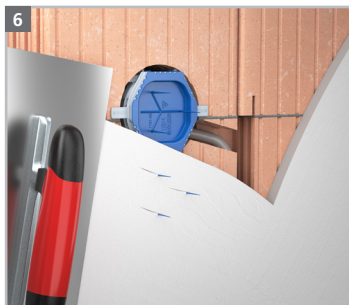

Bei Verwendung von Dünnputz sind die Dosen zusätzlich mit Unterputz-Pistolschaum zu fixieren! / When using thin plaster, the boxes must be additionally fixed with flush-mounted spray foam! / En cas d'utilisation d'un enduit mince, les boîtes doivent être avec de la mousse pour pistolet à encastrer! / Als er dun pleisterwerk wordt gebruikt, moeten de dozen worden afgedicht met vlakschuim! / Se si utilizza un intonaco sottile, le scatole devono essere sigillate con schiuma piatta!

UP¹ ECON[®] Fix

Montage mit Schaum / Assembly with foam / Montage avec mousse / Montage met schuim / Montaggio con schiuma

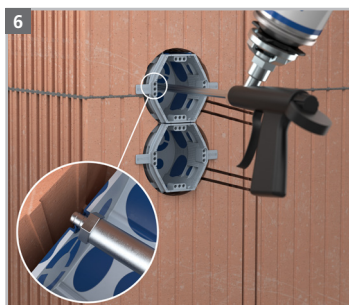
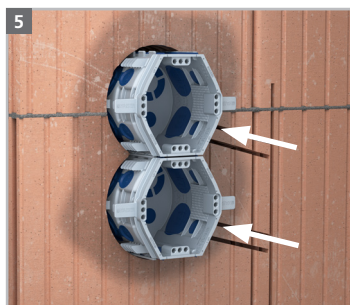

UP¹ ECON[®] Fix

Montage mit Schaum / Assembly with foam / Montage avec mousse / Montage met schuim / Montaggio con schiuma

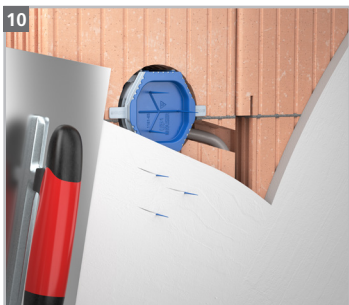
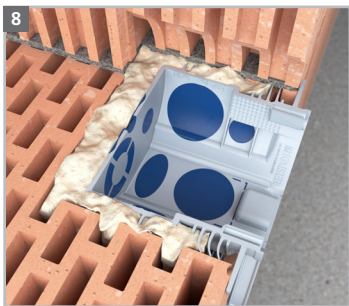
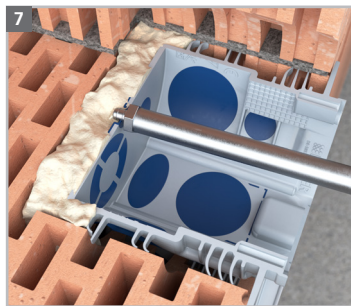

UP¹ ECON[®] Fix

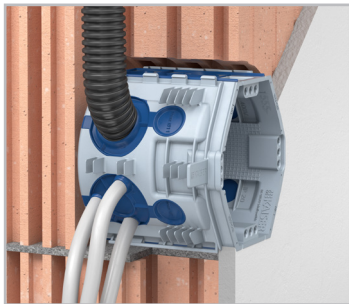

Durch das Eindringen des Putz wird die Festigkeit der Dose in der Wand sichergestellt!

/ The strength of the box in the wall is ensured by the infiltration of the plaster! / La pénétration du plâtre assure la solidité de la boîte dans le mur !/ De penetratie van het pleister zorgt voor de stevigheid van de doos in de muur! / La penetrazione dell'intonaco assicura che la scatola sia solida nel muro.



Nicht bei Lehmputz verwendbar!

Cannot be used with clay plaster!
Ne pas utiliser avec de l'enduit d'argile!
Niet gebruiken met leempleister!
Non utilizzare con intonaco di argilla!

Für alle gängigen Steine / For all common stone types / Pour toutes les pierres communes / Voor alle gangbare stenen / Per tutte le pietre comuni

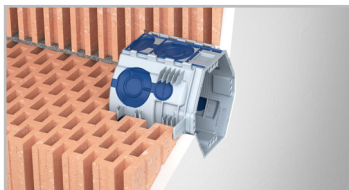

Hochlochziegel mit und ohne Füllung, Vollziegel / Perforated bricks with and without filling, solid bricks / brique perforée verticalement avec et sans remplissage, brique pleine/ verticaal geperforeerde baksteen met en zonder vulling, massieve baksteen / mattone perforato verticalmente con e senza riempimento, mattone pieno

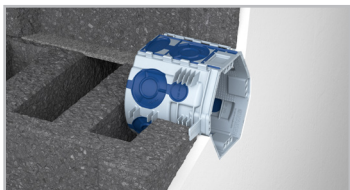

Leichtbeton / Lightweight concrete / Béton léger / Lichtgewicht beton / Calcestruzzo leggero

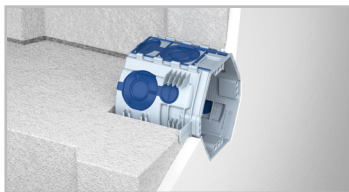

Porenbeton / Aerated concrete / Béton cellulaire / Cellenbeton / Cemento aerato

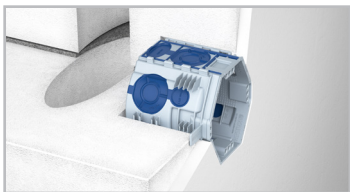

Kalksandstein / Sand-lime brick / Brique silico-calcaire / Kalkzandsteen / Pietra arenaria calcarea

UP¹ ECON[®] Fix

Kombination nach dem Verputzen öffnen / Open the combination after plastering / Ouvrir la combinaison après l'enduit / Combinatie na het pleisteren openen / Aprire la combinazione dopo la stuccatura

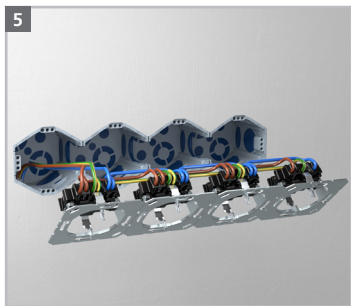
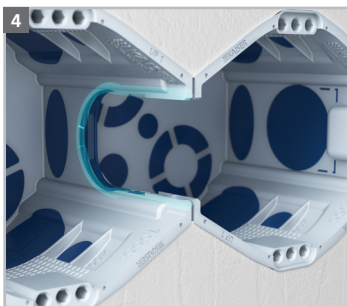
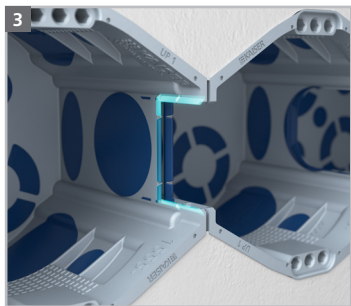
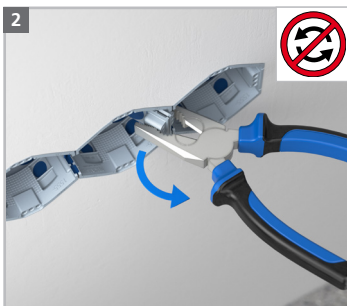
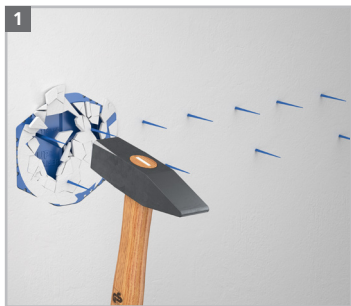

UP¹ ECON[®] Fix

Putzausgleich / Plaster levelling / Égalisation avec l'enduit / Pleistercompensatie / Livellare l'intonaco

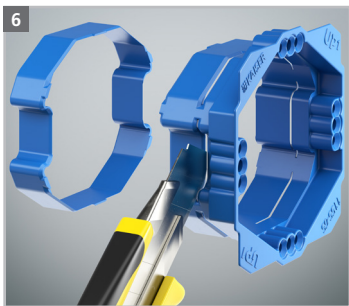
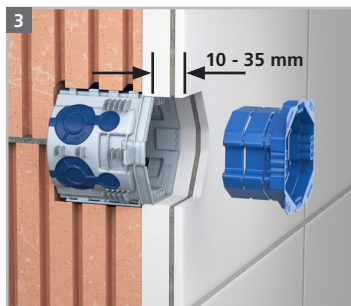
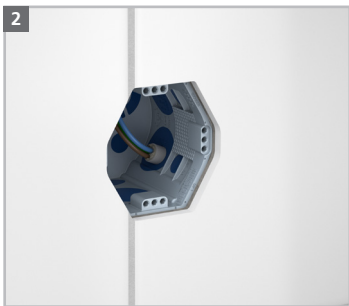

Unterputz-Dosen mit Schnellfixierung / Flush-mounting installation boxes with quick fixing /
Boîtes d'encastrement à fixation rapide / Inbouwdoos met snelverbinder / Scatole sotto-into-
naco con fissaggio rapido

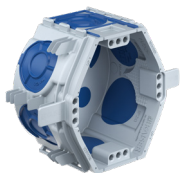

1055-26



1555-26



1155-95



1181-65



1155-65

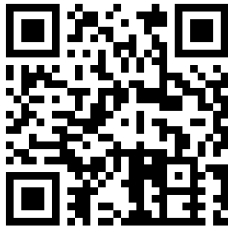

- ⓁⒺ Smartphone? Sehen Sie sich einfach und schnell das Video zur Installation an! QR Code scannen und los gehts!
- ⓁⒺ Smartphone? Just watch the installation video, scan the QR code and get started!
- ⓁⒻ Un smartphone? Il vous suffit alors de consulter la vidéo d'installation! Scannez le code QR et c'est parti!
- ⓁⒼ Smartphone? Bekijk snel de installatievideo! QR-code scannen en klaar!
- ⓁⒽ Smartphone? Guardi semplicemente il filmato di installazione, scannerizzi il codice QR, e potrà iniziare!